

City of DuBois – PERMIT APPLICATION

P. O. Box 408, 16 West Scribner Ave - DuBois, PA. 15801

Phone: 814-371-2000

Fax: 814-375-2307

Permit No. _____

LOCATION OF PROPOSED WORK OR IMPROVEMENT

Municipality: _____ Tax Parcel # _____

Site Address: _____

Lot# _____ Subdivision/Land Development: _____ Phase: _____ Section: _____

Owner: _____ Phone# _____ Fax# _____

Mailing Address: _____ Email: _____

Principal Contractor: _____ Phone# _____ Fax# _____

Mailing Address: _____

Architect: _____ Phone# _____ Fax# _____

Mailing Address: _____ Email: _____

TYPE OF WORK OR IMPROVEMENT (Circle all that apply)

New Building Addition Alteration Repair Demolition Relocation
Change of Use Plumbing Electrical Mechanical Other _____

Describe the Proposed work: _____

ESTIMATED COST OF CONSTRUCTION (Reasonable fair market value) _____

DESCRIPTION OF BUILDING USE (Check one then complete applicable info)

RESIDENTIAL
Single Family Dwelling
Duplex
Townhouse
Total Sq. ft. of finished living space _____

NON-RESIDENTIAL (Commercial)
Specific Use _____
Use Group: _____ Construction Type: _____
Change of Use (indicate former and proposed): _____
Maximum Occupant Load: _____
Maximum Live Load: _____

Sprinkler system to be installed: (Check one) Yes _____ No _____

BUILDING DIMENSIONS

Existing Building Area: _____ sq. ft. Number of Stories: _____
Proposed Building Area: _____ sq. ft. Height Above Grade: _____ ft.
Total Building Area: _____ sq. ft. Area of Largest Floor: _____ sq. ft.

FLOODPLAIN INFORMATION

Is the site located within an identified flood plan area? (Check one) Yes _____ No _____

Note: All proposed development shall be in accordance with the requirements of the National Flood Insurance Program and the Pennsylvania Flood Plain Management Act.

HISTORIC DISTRICT INFORMATION

Is the site located within a Historical District? (Check one) Yes _____ No _____

Note: If yes, you must provide proper Historical District certification per the UCC Law.

The applicant certifies that all information on this application is correct and the work will be completed in accordance with the “approved” construction documents and PA Act 45 – Uniform Construction Code and any additional approved building code requirements adopted by the Municipality. The property owner and applicant assumes the responsibility of locating all property lines, setback lines, easements, right of ways, flood areas, etc. Issuance of a permit and approval of construction documents shall not be construed as authority to violate, cancel or set aside any provisions of the codes or ordinances of the Municipality or any other governing body. The applicant hereby certifies he/she understands all applicable codes, ordinances and regulations.

Application for a permit shall be made by the **owner or lessee of the building or structure, or authorized agent of either, or by the authorized registered Design Professional** employed in connection with the proposed work.

I certify that the Code Administrator or the Code Administrator’s authorized representative shall have the authority to enter areas covered by such permit at any reasonable hour to enforce the provisions of the applicable codes to such permit.

Signature of Owner or Authorized Agent

Print Name of Owner or Authorized Agent

Address: _____

Date: _____

Directions to Worksite: _____

OFFICE USE ONLY below

Permit Fee: \$ _____

Plan Submittal Checklist Attached: yes _____ no _____

Plan Review Approval Date: _____

MUNICIPAL PRIOR APPROVAL CHECKLIST

Name of Municipality_____

Name of Applicant_____

Parcel#_____ Lot#_____

This Section below to be completed by the Authorized Municipal Representative

CHECKLIST ITEMS

Is the project site located in a Flood Area? (Check one) yes____ no____

(Circle one)-----**Residential Project** or **Commercial Project**

Description of Work: _____

Zoning or Land Use Permit Approved_____ Not applicable_____

Stormwater Management Approved_____ Not applicable_____

Street cut/ Driveway Approved_____ Not applicable_____

Sewage/Onlot Permit Approved_____ Not applicable_____

Water Permit Approved_____ Not applicable_____

PennDot Highway Occupancy Approved_____ Not applicable_____

Floodplain Permit Approved_____ Not applicable_____

Other _____ Approved_____ Not applicable_____

I certify that all required Municipal Codes, Ordinances and Regulations have been met and approval thereby is granted to issue the requested Permit.

Authorized Municipal Representative signature:_____

Date:_____

****NOTE THAT THIS PERMIT APPLICATION PACKAGE MUST BE COMPLETED AND THEN SUBMITTED WITH THE PROJECT CONSTRUCTION PLANS AND THE CORRESPONDING SUBMITTAL CHECKLIST****

City of DuBois

RESIDENTIAL POST AND BEAM SUBMITTAL HANDOUT REQUIREMENTS

This submittal form can be used for construction projects such as post and beam framing or pole buildings.

Every item below should be checked as completed (if applicable), or marked n/a (if not applicable), for your project. This form must be completed in its entirety then returned with attached drawings.

- Permit Application
- Municipal Prior Approval Form
- Two full sets of plans. All dimensions must be indicated and drawn to scale.

****The following items are required to be included on the Building Plan Drawings:****

- Site plan showing setbacks
- Floorplan drawing looking down at building
- Exterior elevations
- All applicable information on the Post and Beam cross section
- Size of building (in feet) is: length _____ and width _____
- Draw all post and beam locations on plan
- Type of posts: _____
- Spacing of posts: _____
- Type of Header Beam: _____
- Span of Header Beam: _____

****THIS COMPLETED FORM MUST BE SUBMITTED WITH PROJECT PLANS****

****Always remember to contact "PA One Call" at 800-242-1776 before you dig****

Pole Barn Construction

Side Elevation

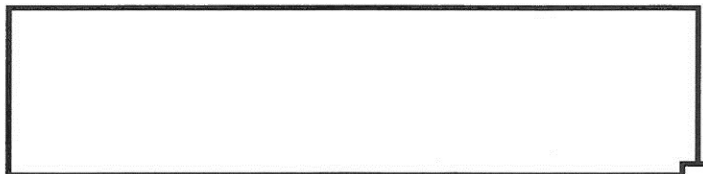
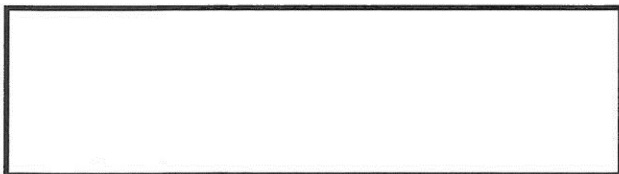
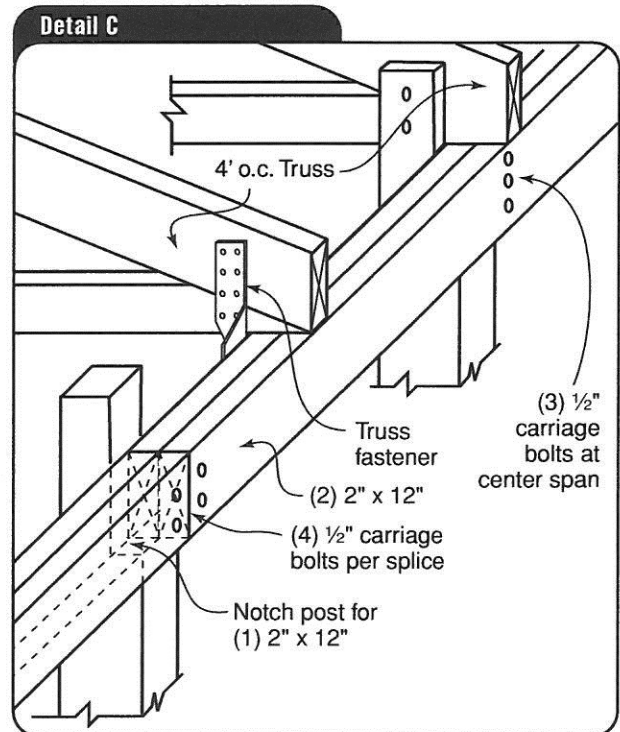
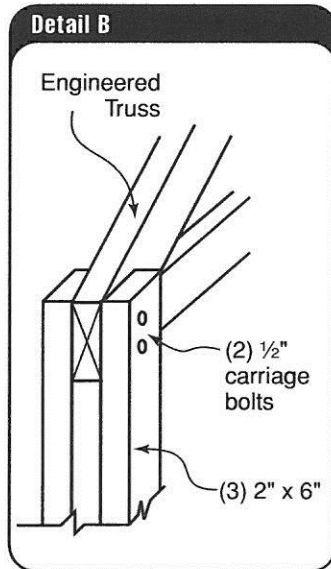
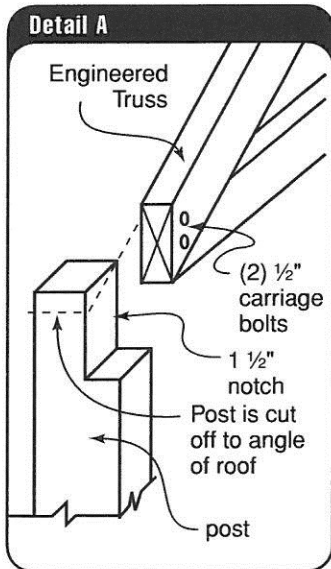
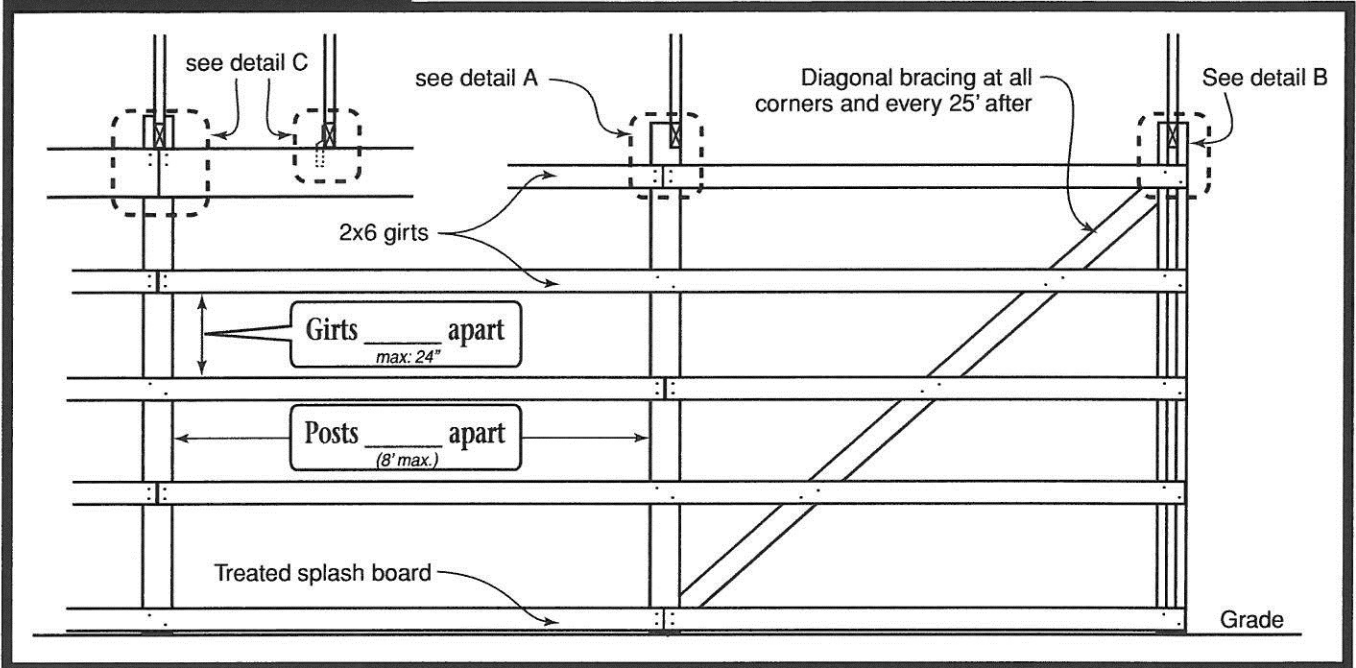

Pole Barn Construction

Floor plan

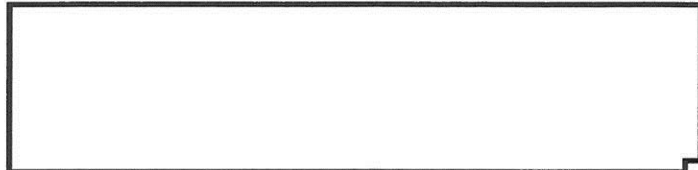
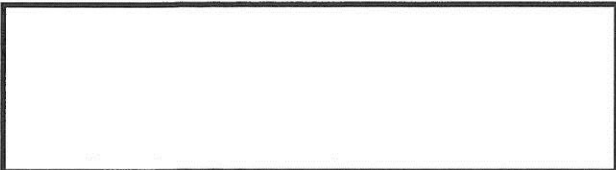
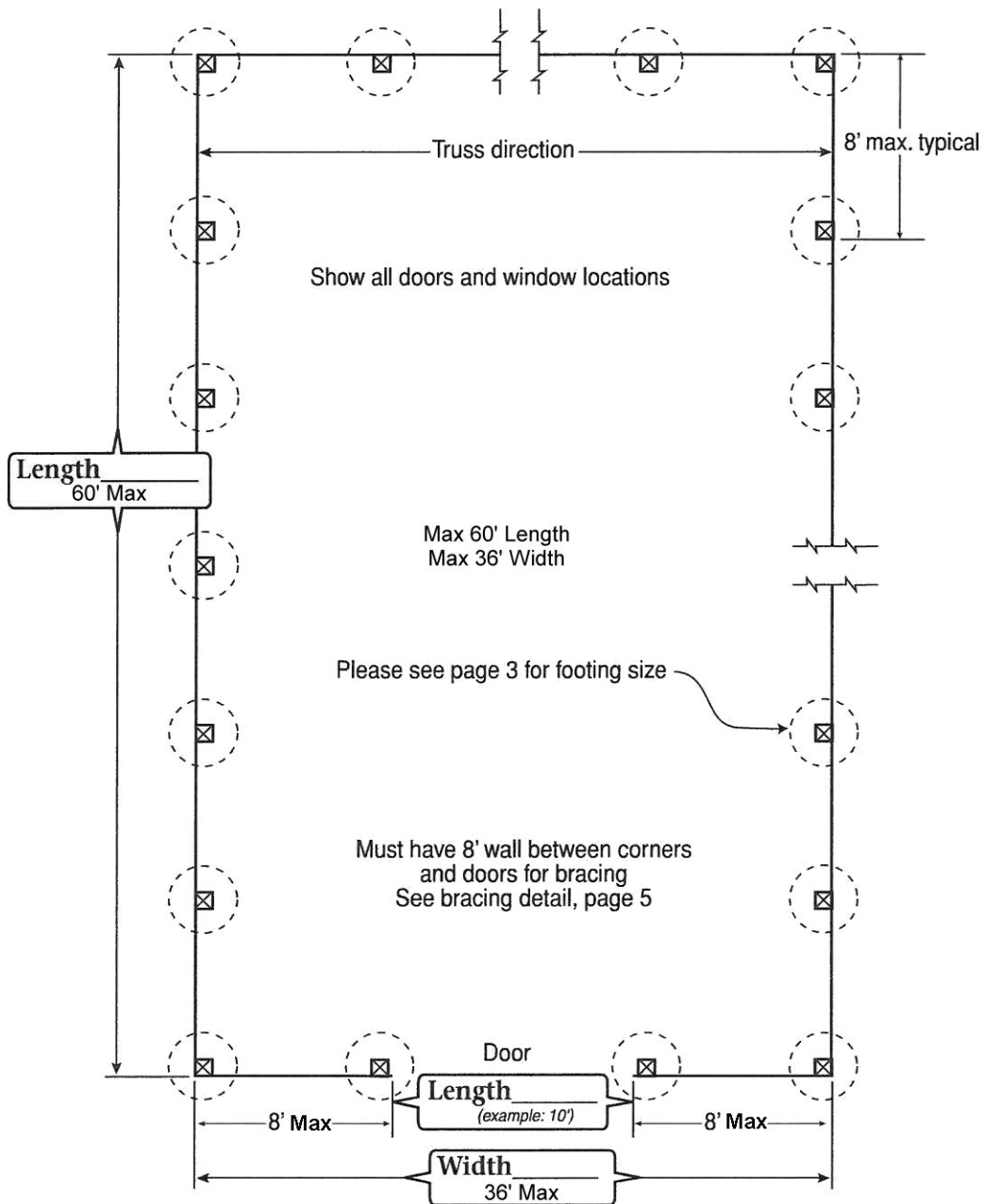

Pole Barn Construction

End Elevation

